



# Rascal AutoGo™

## Owner's Manual



The Rascal Company  
1 Mobility Plaza., Sewell, NJ 08080

---

**Please read this entire manual before operating the vehicle. Failure to do so may result in damage to the vehicle or serious injury.**

The Rascal Company wishes to thank you for choosing the revolutionary Rascal AutoGo™ vehicle for fun and convenience. As the World's leader in the design and production of personal mobility vehicles, we take great pride in our ability to improve the quality of life for people desiring more mobility. Your Rascal AutoGo has been thoroughly tested and will give you years of good service and pleasure, providing you follow the instructions and precautions in this manual. Please review this manual in its entirety prior to first using your equipment and direct any questions you might have to your authorized provider or write/call:

**The Rascal Company**

**USA**  
1 Mobility Plaza  
Sewell, NJ 08080  
1-(800) 257-7955

**Canada**  
1535 Meyerside Drive, Unit #13-14  
Mississauga, ON L5T 1M9  
(905) 565-1988

**United Kingdom**  
Canal Way  
Ilminster, Somerset, England TA19 9DL  
01460-258100

**International:** 1-(856) 468-1000

**Please keep this manual handy for easy reference.  
Please record your vehicle information for future reference:**

**RascalAutoGo™**

**Serial Number:** \_\_\_\_\_

**Date of Purchase:** \_\_\_\_\_

# CONTENTS

Title	Page	Title	Page
<b>Safety Information</b> .....	1	Curbs and Small Obstacles .....	23
<b>Getting to Know Your Rascal AutoGo</b> .....	5	Freewheel Operation .....	23
<i>Illustration 1 — Rascal AutoGo Components</i> .....	6	Automatic Folding and Unfolding .....	24
Initial Set-up .....	7	Folding Instructions .....	24
Unfolding .....	7	<i>Illustration 6 — Folding Seatback Down</i> .....	24
Charging Batteries .....	8	<i>Illustration 7 — Dash Release Lever</i> .....	25
<i>Illustration 2 — Battery Charging</i> .....	9	<i>Illustration 8 — Foot Release &amp; Frame Lock</i> .....	25
Installing the Battery Pack .....	11	<i>Illustration 9 — Folding Operation</i> .....	27
<i>Illustration 3 — Battery Pack Installation</i> .....	11	Unfolding Information .....	28
Adjusting Tiller Position .....	12	Flat Folding and Unfolding .....	29
<i>Illustration 4 — Tiller Adjustment Lever</i> .....	12	<i>Illustration 10 — Flat Fold</i> .....	29
Installing & Setting the Dashboard Clock .....	13	<i>Illustration 11 — Unfolding Flat Folded Vehicle</i> .....	30
Controls .....	14	Disassembly & Re-Assembly .....	31
<i>Illustration 5 — Controls</i> .....	14	Taking the Rascal AutoGo Apart .....	31
<b>Operating the Rascal AutoGo</b> .....	19	<i>Illustration 12 — Seat Removal</i> .....	31
Daily Use .....	19	<i>Illustration 13 — Flattening Seat Frame</i> .....	32
Transferring On or Off the Vehicle .....	20	<i>Illustration 14 — Quick Release Drivetrain Lever</i> .....	33
Driving .....	20	<i>Illustration 15 — Remove Quick Release Drivetrain</i> .....	33
Speed Settings .....	22	Re-assembling the Rascal AutoGo .....	34
Inclines .....	22	<i>Illustration 16 — Align Rear Frame to Drivetrain</i> .....	34
Cornering & Turning .....	22	Transporting the Rascal AutoGo .....	36

Title	Page	Title	Page
<b>Maintenance</b> .....	38	<i>Illustration 17— Cable Turnbuckle Adjustment</i> .....	42
Preventative Maintenance .....	38	Drivetrain .....	43
Frame Inspection .....	38	Seat Frame Cams .....	43
Headlight .....	39	Replacing Clock Battery .....	44
Lubrication .....	39	<i>Illustration 18 — Replacing Clock Battery</i> .....	44
Tires .....	40	Troubleshooting Guide .....	46
Electrical Connections .....	40	Controller Fault Codes .....	48
Hardware Inspection .....	40	Parts Ordering Procedures .....	49
Cleaning Instructions .....	40	Accessories .....	50
Polishing .....	41	<b>Specifications</b> .....	51
Cable Adjustment .....	41	<b>Warranty</b> .....	52

## ILLUSTRATIONS

Number	Title	Page	Number	Title	Page
1	Rascal AutoGo Components .....	6	10	Flat Fold .....	29
2	Battery Charging .....	9	11	Unfolding Flat Folded Vehicle .....	30
3	Battery Pack Installation .....	11	12	Seat Removal .....	31
4	Tiller Adjustment Lever .....	12	13	Flattening Seat Frame .....	32
5	Controls .....	14	14	Quick Release Drivetrain Lever .....	33
6	Folding Seatback Down .....	24	15	Remove Quick Release Drivetrain .....	33
7	Dash Release Lever .....	25	16	Align Rear Frame to Drivetrain Frame .....	34
8	Foot Release & Frame Lock .....	25	17	Cable Turnbuckle Adjustment .....	42
9	Folding Operation .....	27	18	Replacing Clock Battery .....	44

©2003 The Rascal Company  
 Rascal AutoGo™ is a trademark of The Rascal Company  
 Patents Pending

No liability is assumed with respect to the use of any information contained in this publication. While every precaution has been taken in the preparation of this publication, The Rascal Company assumes no responsibility for errors or omissions nor is any liability assumed for damages resulting from the use of information contained in this publication. This publication, as well as operational details described herein, are subject to change without notice.

## Safety Information

Read and understand these Warnings and the entire manual before using your Rascal AutoGo. Failure to follow these instructions may result in damage to the vehicle or serious injury.

### **IMPORTANT!**

1. **DO NOT** exceed the specifications of this unit, modify this unit in anyway, or use the unit for a purpose other than as intended.
2. **DO NOT** operate this unit if your health or medications you are taking cause you to feel dizzy, affect your vision, or in any way impact your thought process, coordination, or ability to safely operate the unit. Check with your physician should you experience any of these symptoms.
3. **DO NOT** operate this unit after consuming any alcoholic beverages.
4. **DO NOT** transfer “on” or “off” the unit until it is turned “OFF”, completely stopped, and when it is on a stable and level surface.
5. **DO NOT** attempt to ride over curbs or other obstruction higher than 1 inch.
6. **DO NOT** stop when going up an incline. If you must do so, always lean forward to shift the center of gravity and prevent the unit from tipping.
7. **DO NOT** climb inclines that pose a concern for stability.
8. **DO NOT** drive across an incline or attempt to turn while on an incline.

9. **DO NOT** back down an incline or allow the unit to be backed down an incline. the unit.
10. **DO NOT** turn off the power while the unit is moving.
11. **ALWAYS** remember vehicle capacity is limited to one person only. This unit is not approved for towing or for weights in excess of the published maximum.
12. **ALWAYS** drive straight up and down inclines.
13. **ALWAYS** turn the power off when the unit is not in use. This will not only extend the life of the charge in the battery but will keep the unit from being accidentally moved.
14. **ALWAYS** use a grounded receptacle. Use of a non-grounded receptacle could result in an electrical shock.
15. **ALWAYS** reduce speed when making a turn.
16. **ALWAYS** keep arms and legs within the confines of
17. **USE EXTRA CAUTION** when climbing inclines (ramps, hills, driveways, etc.).
18. **USE CAUTION** when braking on an incline or wet or slippery surfaces as the unit may take longer to come to a complete stop.
19. **USE CAUTION** when operating the unit in bad weather or driving through water as moisture could affect the control system or other parts of the unit either temporarily or permanently.
20. **OPERATOR** must remain seated when the unit is moving.
21. **NEVER** hose off your vehicle.
22. **NEVER** use your unit in a shower or steam room.
23. **NEVER** charge batteries that may be frozen.

## **Important Information Regarding Electromagnetic Interference (EMI)**

It is very important that you read this information regarding the possible effects of electromagnetic interference (EMI) on your vehicle.

Electromagnetic interference (EMI) refers to the effects that outside sources of electromagnetic energy (radio and television broadcasts, CB radios, garage door openers, etc.) might have on the control systems of your vehicle. The interference from these sources could cause the vehicle to release its brakes, move by itself, or to move in an unintended direction. EMI could also result in permanent damage to the control system.

The sources of electromagnetic energy can be broadly classified into three types:

- Hand held short-range portable transceivers — These are transmitter/receivers with the antenna mounted directly on the unit. Examples include: citizen band (CB) radios, “walkie-talkies”, security, fire and police transceivers, and devices that transmit signals even when not in use.
- Medium range mobile transceivers — These usually have the antenna mounted outside of a vehicle or building. Examples include police, fire, and ambulance and taxi transceivers.
- Long range transmitters and receivers — These usually have the antenna mounted on a tower. Examples include commercial radio and television broadcasts and amateur (HAM) radios.



Other types of hand-held devices like cellular telephones, laptop computers, AM/FM radios, and small appliances like hair dryers or electric shavers may also generate electromagnetic energy, but it is such a small amount that, as far as we know, no EMI problems should occur with these devices.

The intensity of interference from electromagnetic energy is measured in volts per meter (v/m), which refers to the strength of the electrical source (voltage) as it relates to the distance away from the object being considered (in meters). Resistance of a vehicle to a certain EMI intensity is commonly called its "immunity level." A level of 20 volts/meter is a generally achievable and useful immunity level against interference from radio wave sources (the higher the immunity level, the greater the protection).

Your vehicle has been tested and found to meet the required immunity level for Electromagnetic Interference (20 v/m).

Report all incidents of unintended movement or unexpected brake releases to Electric Mobility's customer service department.

### **WARNING!**

**Even with an immunity level of 20 volt/meter, certain precautions must be followed to ensure that your vehicle will not be affected by outside electromagnetic sources.**

---

## Getting to Know Your Rascal AutoGo

**Dash & Controls** — The Rascal AutoGo is operated from the controls located on the dashboard and the Forward/Reverse lever which controls the power folding/unfolding feature. Detailed descriptions of these controls are presented in a separate part of this section (see “Controls” on page 14).

**Serial Number** — Each Rascal AutoGo is identified by a unique, 8-character Serial Number located on a label on the inside of the tiller, behind the Battery Pack. When you first get your vehicle, remove the Battery Pack and write down the vehicle's Serial Number in the front of this manual (see page i) for future reference.

**Tiller & Battery Pack** — The front, steerable tiller directs the Rascal AutoGo into your desired direction of movement. A removable Battery Pack is mounted on the front of the Tiller. This Battery Pack also contains the integral Battery Charger. A separate Charger Power Cord is used to recharge the batteries from any 3-prong wall electrical outlet.

**Seat** — A removable, adjustable, padded seat provides riding comfort when using your Rascal AutoGo. Folding backrest and armrests allow for compact storage.

**Folding Chassis** — The hinged, articulated chassis of the Rascal AutoGo allows it to automatically fold and unfold for use and storage.

**Drivetrain** — A removable Drivetrain mounted at the rear of the chassis provides power to drive the Rascal AutoGo vehicle and to power fold it. A self-contained parking brake has a manual release which allows the vehicle to be manually pushed without operating the motor.

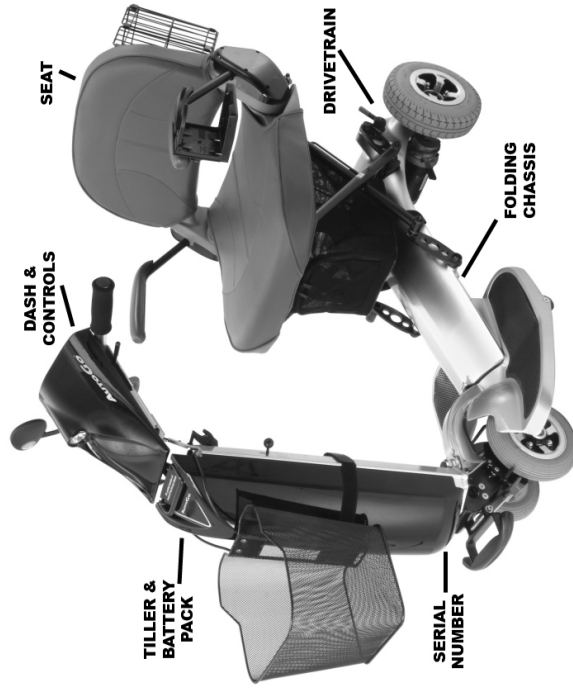

Illustration 1 — Rascal AutoGo Components

## **Initial Set-up**

After receiving and unpacking your Rascal AutoGo use the following to initially set-up the vehicle. Set-up consists of unfolding it from the flat-fold configuration, installing the Battery Pack, installing/setting the dashboard clock, and charging the batteries.

## **Unfolding**

The Rascal AutoGo is initially shipped in the flat fold configuration and must be unfolded for use. Unfold the Rascal AutoGo according to the following:

- Raise tiller and dash to upright position
- Raise seat frame and lock into position using the Seat Frame Cams
- Install seat onto frame
- Raise seat backrest to driving position

## Charging Batteries

The Rascal AutoGo is equipped with two maintenance-free, airline approved, sealed 12V/15A batteries with an integral automatic battery charger mounted in a detachable Battery Pack installed onto the front of the tiller. Because your batteries may only have a partial charge when you first receive your vehicle, you may not experience full riding time until you have fully charged them. Charging your batteries as specified in the following instructions will ensure maximum life, power, and range.

It is recommended to charge your batteries:

- Upon initial receipt of your Rascal AutoGo
- For 6-8 hours (overnight) after extended use during the day
- Whenever the fuel gauge indicator goes into the red area (see *page 17*)
- The battery's life expectancy may be shortened if batteries are left fully discharged for more than a day

Battery Pack and power cord connections are shown in Illustration 2.

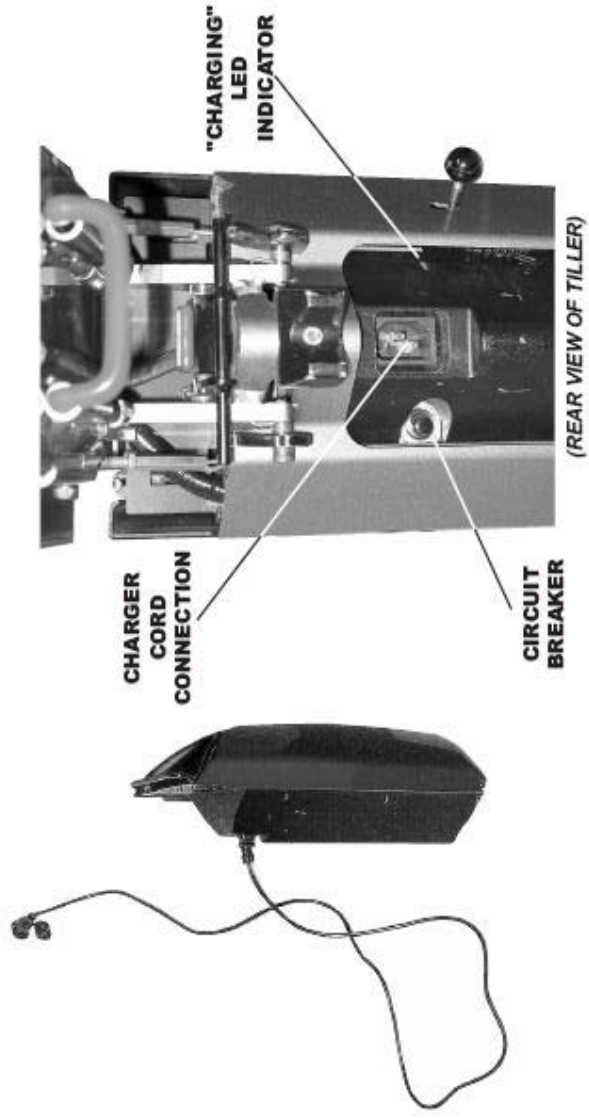

Illustration 2 — Battery Charging

Charge the batteries as follows:

1. For your convenience, you can detach the Battery Pack from the Rascal AutoGo and move it to a 3-Prong Grounded Electrical Receptacle. If you choose, you can also park the Rascal AutoGo near a 3-Prong Grounded Electrical Receptacle without removing the Battery Pack.

### **WARNING!**

**Use of a non-grounded receptacle could result in an electrical shock.**

2. Use the separate Charger Power Cord, included in kit with this Owners Manual, and plug it into the 3-Prong Grounded Electrical Receptacle on the rear of the Battery Pack. Your Charger Power Cord is equipped with either a 110V or 220V plug. If you wish to purchase either cord for travel to different countries, contact the Customer Service Department to purchase a cord for 220V (UK), 220V (Europe), 100V (Japan) locales.
3. Check that the LED on the rear of the Battery Pack is lit. This indicates that the Charger is recharging the batteries.
4. Normal charging time is generally 6-8 hours for fully discharged batteries.
5. Disconnect the Charger Power cord from the Battery Pack and wall outlet. We recommend that you keep the cord in the storage pouch underneath the seat so it is readily available.

**Note:** Do not operate vehicle while charging.

## Installing the Battery Pack

After the batteries have been fully charged, you'll be ready to install the Battery Pack into the Tiller. Install the battery pack as follows (see Illustration 3).

1. Lift the Battery Pack by the handle and insert the bottom of the Battery Pack into the bottom of the Tiller. Line up the slot under the pack with the bar on lower shelf of tiller.
2. Firmly push the top front of the Battery Pack into the tiller until it "snaps" in place. Ensure that the (5) pin tiller connector mates tightly with the connector of the Battery Pack.
3. Make sure the handle on the battery pack is fully returned to its seated position to lock the Battery Pack in place.



Illustration 3 — Battery Pack Installation



## Adjusting Tiller Position

For your riding comfort, the Rascal AutoGo tiller can be used in two positions.

To adjust tiller position:

- Lift Tiller Position Adjustment Knob to release tiller lock
- Adjust tiller to preferred position
- Release knob to lock in place

This adjustment lever is shown in Illustration 4



Illustration 4 — Tiller Adjustment Lever

## Installing & Setting the Dashboard Clock

Your Rascal AutoGo comes with a removable, battery-powered, quartz clock that mounts directly in the dash. This clock is packed separately to allow you to set it to your local time before installing in the dash.

**Setting the Clock** — Locate the bag containing items packed separately with the vehicle. Unwrap the clock from its protective packing. If clock includes a small, plastic collar around stem, remove collar and push stem “in” to start clock.

Set clock to your local time by pulling stem out and turning to adjust hour/minute hands. Push stem in to start clock.

**Installing the Clock** — When you have set the clock to your correct, local time, you can install it in the dash of your vehicle. Install the clock into the location adjacent to the Speed Control. The rubber gasket is sufficient to secure the clock in place. Make sure the “12” faces “up.”

## Controls

The Rascal AutoGo includes the following controls (Illustration 5) used to operate the vehicle. Individual descriptions of each control are presented in pages 15-18.

Illustration 5 — Controls

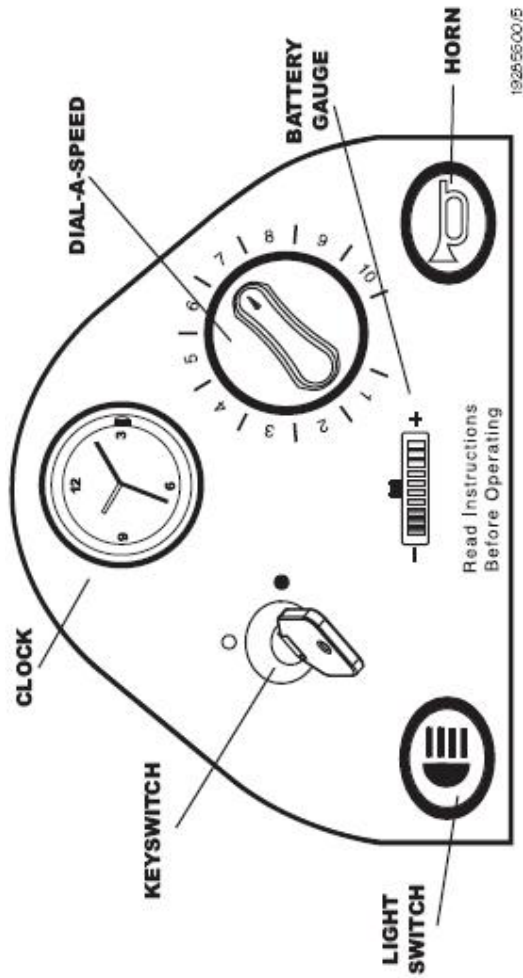

## Keyswitch

To turn power on, turn the key to the "On" position (indicated by a solid black circle). To turn power off, turn key to "Off" position (indicated by an open circle). The Battery Gauge (Fuel Gauge) should be lit when the key is in the "On" position.

Use of a key to turn the Rascal AutoGo on and off also protects against unauthorized use of your Rascal AutoGo.

## Battery Power Save Feature

The Rascal AutoGo is equipped with a power save feature and, will shut down automatically in order to conserve battery power when not operated for 10 minutes or more. The vehicle can be turned on again by cycling the ON/OFF keyswitch from ON to OFF and then ON again.

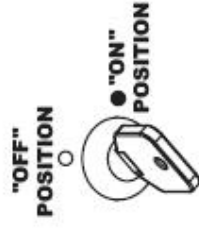

## Dial-A-Speed Knob

The Dial-A-Speed regulates the potential speed of the Rascal AutoGo. We strongly recommend setting it at 2 or 3 until you feel confident with controlling your vehicle properly. Turning the speed dial counter-clockwise decreases the top potential speed. Turning it clockwise (up to "10") provides speed up to maximum potential speed.



## Forward/Reverse Lever

To operate the Rascal AutoGo in the forward direction, gradually squeeze the right side of the engager lever towards the handle grip. To move in reverse, squeeze the left side of the engager lever towards the handle grip. The forward/reverse lever controls are proportional up to the top speed of the setting of the Dial-A-Speed knob. Gradually squeezing the lever allows smooth starts and lets you fully control all speeds with one lever. The engager lever is also used for "power fold/unfold the vehicle (see "Automatic Folding and Unfolding" on page 24).

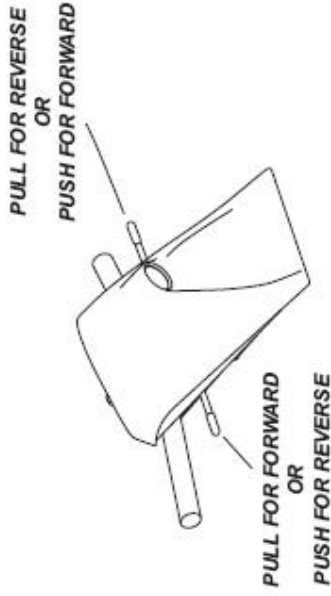

## Battery Gauge (Fuel Gauge)

The Rascal AutoGo includes an illuminated Battery Gauge that provides a visual indication of the electrical charge in the Battery Pack. It consists of 10 different LED bars (3 red, 4 amber and 3 green), that are lit in accordance with the state of battery charge.

- If all bars are lit — indicates Battery Pack is fully charged
- If only red and amber bars are lit — indicates Battery Pack charge is low
- If only red bars are lit or flashing — indicates Battery Pack requires immediate recharging

The Battery Gauge also functions as a Status Indicator to troubleshoot and identify problems with the Rascal AutoGo or controller. If Battery Gauge is flashing, see “*Controller Fault Codes*” on page 48.

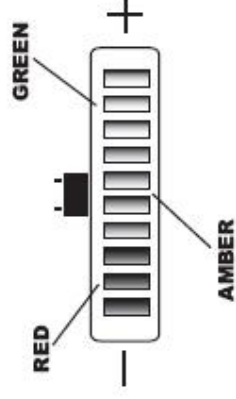

## Horn

Pressing the horn button on the dash sounds the horn to alert pedestrians of your approach. You may also find it helpful to use it when rounding blind corners or going in reverse.



## Light Switch

Depress the switch button to turn the headlight ON. Depress the switch button again to turn the headlight OFF.



## Clock

For convenience, the dash of the Rascal AutoGo includes a battery-powered, analog clock displaying the current time of day. Instructions to set the time and install the clock are provided in the “*Initial Set-up*” section of this manual (see page 13). Instructions to replace the clock battery are provided in the “*Maintenance*” section of this manual (see page 38).



## Operating the Rascal AutoGo

Once you've become familiar with the Rascal AutoGo components, controls, and have charged the Battery Pack, you can use the following section to operate it. This section presents instructions for getting on and off your vehicle, as well as driving it. It also details pushing it in freewheel mode and pulling it in freewheel mode.

If you are unsure of how to operate your Rascal AutoGo vehicle, go back to the previous section before attempting any use.

### Daily Use

The following describes using your Rascal AutoGo during general, daily operation, including:

- Transferring On & Off
- Driving
- Freewheel Operation

Additional information, including automatic folding/unfolding and disassembling the Rascal AutoGo for transport and storage is presented in a subsequent section (see [page 24](#)).



## Transferring On or Off the Vehicle

Your Rascal AutoGo has been designed to make transferring on and off the vehicle as easy as possible.

### **WARNING!**

**Make sure key switch is either in the OFF position or the key is removed before transferring ON or OFF the vehicle.**

Use the following recommendations to assist you in making a more comfortable transfer.

- The Dash can be lifted up away from the tiller for greater clearance when getting on or off.
- Use the Tiller Adjustment Knob to move Tiller away from seat for ease of transfer.
- Lift the folding armrests of the seat up and out of your way. Be sure to move them down into the riding position before operating the Rascal AutoGo.

## Driving

Once seated on your Rascal AutoGo vehicle, driving is as simple as using the Engager Lever to move forward or reverse and steering in the desired direction. Before driving the Rascal AutoGo vehicle, however, you should keep in mind the following recommendations.

---

1. Tiller and dash are locked in position, facing the operator.
2. Frame Pivot Lock is engaged.
3. Seat is locked onto frame. Check latching lever.
4. Drivetrain is properly aligned and connected to frame.
5. Drivetrain clicks into position and locked.
6. Parking brake engaged. Check Brake Lever. Should be in "UP" position.
7. Armrests are lowered into driving position.

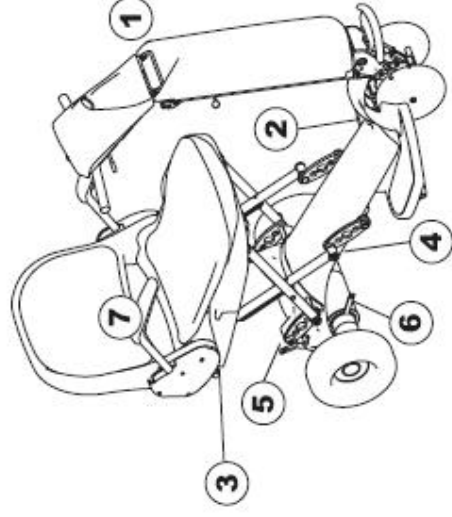

**WARNING!**

**If any of these items are questionable, DO NOT OPERATE! Check before driving.  
Adverse conditions may cause accidents or injuries.**

## Speed Settings

The overall forward/reverse speed range of the vehicle is selected from the Speed Control knob on the dash. Lower settings result in slower speeds. Higher settings provide faster speeds.

When first operating your vehicle, select slower settings until you feel comfortable.

## Inclines

**ALWAYS** lean forward when traveling up inclines for greater stability.

If vehicle stops on an incline, **DO NOT** attempt to continue climbing.

We do not recommend stopping on an incline.

If vehicle stalls on an incline, back down with the speed set at "slow" and in one continuous movement. **DO NOT** start and stop.

## Cornering & Turning

**ALWAYS** reduce speed when making a sharp turn or going around a corner.



### Curbs and Small Obstacles

**ALWAYS** climb or go down small obstacles slowly to avoid damage to the vehicle.

**DO NOT** attempt to ride over curbs or any other obstructions higher than 1 inch (2.54 cm).



### Freewheel Operation

The Rascal AutoGo features a "freewheel" mode to allow it to be pushed by hand (manual operation). To activate manually, turn the key switch OFF and locate the brake release lever under the rear cover on the right side. Push lever down to disengage the brake release. Move lever up to reengage the brake. When your vehicle is in manual mode, brakes will not operate.

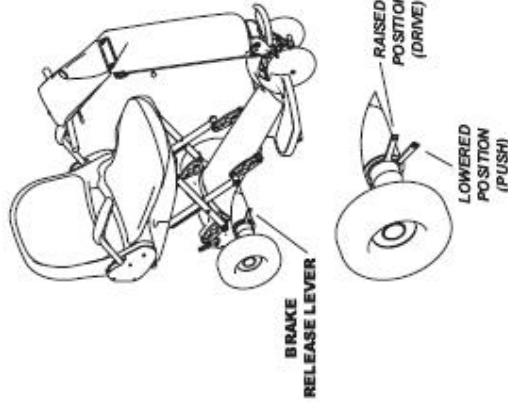

### **WARNING!**

**Never sit in vehicle if it is in "freewheel" mode on an incline.**

## Automatic Folding and Unfolding

A key feature of the Rascal AutoGo is the ability to automatically fold and unfold it for ease of transport, storage, and use. The benefit is one can fold their vehicle without any bending or lifting. Instructions to automatically fold and unfold the Rascal AutoGo are provided in this section.

### Folding Instructions

The Rascal AutoGo can be folded to a compact, vertical package when not in use for transport, or storage. Under its own power, the Rascal AutoGo can be moved out of the way. Use the following procedure to quickly fold the Rascal AutoGo into its vertical folded position. Folding is illustrated in Illustrations 6-9.

1. While standing on the side of the unit, fold seatback down, as shown in Illustration 6.

#### **WARNING!**

**DO NOT attempt to Power Fold your vehicle while seated on it.**



Illustration 6 — Folding Seatback Down

2. Pull Dash Release up and lift dash to upright position to engage wheel locks onto front wheels, see Illustration 7.
3. Position yourself on the right side of the Rascal AutoGo. Press the foot lever, as shown in Illustration 8, to retract the frame lock.

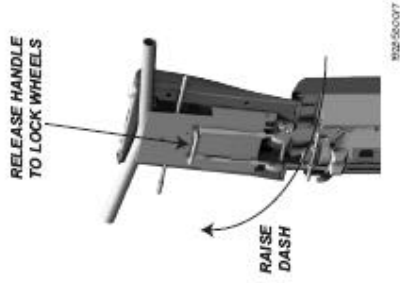

Illustration 7 — Dash Release Lever

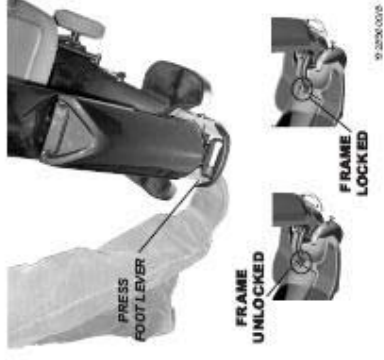

Illustration 8 — Foot Release & Frame Lock

4. Before releasing the foot release lever, lean the tiller forward slightly to start the folding sequence. Remove your foot from foot release lever. Make sure the main frame is above the pivot lock and you are ready to automatically power fold the vehicle.
5. **Pull** the right side Engager lever to activate drive motor and initiate fold. The Rascal AutoGo will automatically fold under its own power and stop.

**WARNING!**

**Folding the vehicle presents a pinch hazard! Be sure to keep hands, body, clothing, jewelry, etc., free from pinch points to avoid accidents or injuries.**



*Illustration 9 — Folding Operation*

6. When fully folded, latch the frame and tiller together by pressing the tiller back against the main frame, see Illustration 9.
7. When folded, lower the dash to release the front wheel locks.
8. Using engager levers, you can operate the Rascal AutoGo forward/backward, as needed.



**WARNING!**

**When moving vehicle in power folded position, use extreme care to avoid tripping or colliding with yourself, others, or other vehicles.**

**Unfolding Information**

Follow these instructions and refer back to illustrations 6-9 to unfold the vehicle using the power unfold feature:

**IMPORTANT!**

**Before attempting to unfold, make sure there is adequate clearance to the rear of the vehicle to accommodate unfolding.**

1. Use keyswitch to turn vehicle "On" and position dash into upright, vertical position by pulling the dash release up and lifting dash to upright position.
2. Release tiller and frame latch, as shown in Illustration 9.
3. **Push** right side engager lever to activate motor to automatically unfold the vehicle.
4. Pull Dash Release to lower dash to driving position. Raise seat back to driving position.

## Flat Folding and Unfolding

As an added convenience, the Rascal AutoGo can be manually folded flat for storage or transport. When folded flat, the Rascal AutoGo can be easily stored in a car trunk, under your bed, or in a storage compartment.

To flat fold the Rascal AutoGo:

- Turn power "OFF". If desired, seat can be removed for more compact storage.
- Flatten seat frame by:
  - Rotating Seat Frame Cams by pushing cam handles down until they lock,
  - Lifting the seat frame up,
  - Pulling seat frame and lifting crossover strap up until seat frame collapses to the rear. Rear cams will return to original position
- Pull Dash Release lever and lift dash to upright position. Then, lower tiller onto frame, as shown in Illustration 10.
- Unit can be secured by engaging frame straps located on either side of bag.

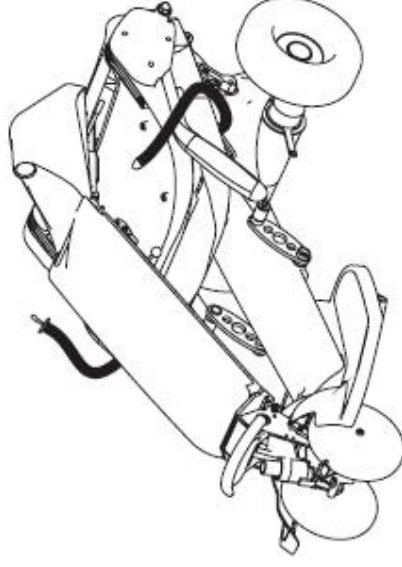

Illustration 10 — Flat Fold (shown with seat on)

To unfold the Rascal AutoGo after being folded flat:

- Raise tiller and dash to upright position
- Pull dash release lever and return dash to driving position
- Raise seat frame and lock into position using the Seat Frame Cams
- Re-install seat (if removed)

Unfolding is shown in Illustration 11. Make sure to test before riding.



Illustration 11 — Unfolding Flat Folded Vehicle

## Disassembly & Re-Assembly

In addition to easily folding and unfolding, the Rascal AutoGo can be quickly and easily disassembled for storage or transport, then re-assembled when needed. Instructions to take your Rascal AutoGo apart and put it back together are presented in this section.

### Taking the Rascal AutoGo Apart

Taking the Rascal AutoGo apart involves removing the seat and Battery Pack, flattening the seat frame, and removing the drivetrain. Instructions to disassemble the Rascal AutoGo appear in the following.

1. Turn power "OFF." Fold seat back down.
2. Pull seat latch bar on rear underside of seat. Lift rear of seat, and slide seat forward to disengage from the frame (see Illustration 12).



Illustration 12 — Seat Removal

3. Lift Battery Pack handle up and pull forward to remove Battery Pack from tiller.
4. Flatten seat frame as shown in Illustration 13, by:
  - Rotating seat Frame Cams by pushing cam handles down until they lock,
  - Lifting the rear of seat frame up,
5. Pull Rear Frame back and lift crossover strap up until seat frame collapses to the rear.
6. Rear cams will return to original position
7. Lift Dash Release and lower tiller onto frame.



*Illustration 13 - Flattening Seat*

8. The Quick Release Drivetrain lever is located at the rear, underneath the frame. Push the red Quick Release Drivetrain Lever with your thumb, as shown in Figure 14. While the lever is pushed, lift rear of the scooter using the crossbar located in front of release lever. The drivetrain will automatically disconnect and remain on ground, as shown in Figure 15.



Illustration 14 - Quick Release Drivetrain Lever



Illustration 15 - Remove Quick Release Drivetrain

**WARNING!**

**Do not push the Drivetrain Quick Release Lever while lifting or transporting scooter. This may result in injury or damage to scooter.**

## Re-assembling the Rascal AutoGo

Putting the Rascal AutoGo back together involves re-attaching the drivetrain, re-positioning the tiller and dash, raising & locking the seat frame, installing the seat, and installing the battery pack for driving operation. Instructions to re-assemble the Rascal AutoGo are provided in this section.

1. Place drivetrain on firm, level surface with drivetrain kickstand facing the front of the Rascal AutoGo.
2. Position rear of frame over top of drivetrain so that slots in the rear of the frame align with struts of the drivetrain, as shown in Illustration 16. Lower rear frame onto drivetrain, then release. Push down on rear of frame until drivetrain clicks into position.



Illustration 16 - Align Rear Frame to Drivetrain Frame

### **WARNING!**

**Removing or replacing Quick Release Drivetrain may present a pinch hazard. To avoid accidents or injuries be sure to keep hands free from labeled pinch points.**

3. Check brake lever is in the locked position (See page 23). Make sure the scooter cannot be moved with the ignition off. Fuel Gauge will flash on & off if Brake is in push mode and key is "On".
4. Position tiller into one of two preferred driving positions.
5. Pull seat frame up into position, making sure crossover bar seats onto folding chassis. Seat Frame Cams will rotate up to lock in position.
6. Replace seat onto frame, making sure latch locks in place.
7. Install Battery Pack into front of tiller (see "Installing the Battery Pack" on page 11).
8. Lower dash to driving position.
9. Turn key to "ON" position. If no power or fuel gauge is flashing, check connection at drivetrain or confirm that brake lever is in drive mode.



## Transporting the Rascal AutoGo

**By Car** — To transport your disassembled Rascal AutoGo by car, place each of the components into the trunk, being careful not to scratch or mark any of the finished surfaces. If you need assistance lifting weights, consider asking Electric Mobility's Customer Service Department or your authorized service center about the Power Trunk Lift. This device will assist you in transporting your Rascal AutoGo by transferring these components in and out of your trunk with very little effort. (See “Specifications” for more information on weights).

**By Airplane** — To transport your Rascal AutoGo on an airplane, we recommend that you notify your airline of your mobility vehicle at least 24 hours prior to departure through your travel agent or in person. Ask your airline or your travel agent whether they will need to disassemble the Rascal AutoGo or whether they plan to load and store it on the plane without disassembly. Ask specifically where and with whom you should drop the unit off and where and with whom you should retrieve it at your destination.

**Note:** Your Rascal AutoGo is equipped with sealed lead acid batteries. These batteries are approved by the Federal Aviation Authority (FAA) for air travel.

Remember to bring this manual with you as a reference on your trip. Your manual will assist you in disassembling and re-assembling your Rascal AutoGo if required.

Prior to leaving the airport, remember to test the Rascal AutoGo when first getting on it. Direct any questions to the airline personnel if the unit does not work as it did prior to transportation.

If traveling outside of the United States, you may require a different charger power cord for your battery pack. Contact Customer Service or your authorized service center can help you answer these questions and supply you with the appropriate charger cord you may require.

**WARNING!**

**This vehicle does not meet Federal Safety Standards for motor vehicle seating. Do not sit, nor permit anyone else to sit, in the seat of the Rascal AutoGo during transportation in a motor vehicle as this poses a significant risk of bodily injury or even death.**

## Maintenance

This section presents information to keep your Rascal AutoGo in peak operating condition, including:

- Preventative Maintenance
- Troubleshooting
- Parts Ordering Procedure

Your Rascal AutoGo requires only minimal maintenance and by setting time aside each month for careful inspection and checking items included in this section, you can be assured of a long, useful life of your Rascal AutoGo vehicle.

### Preventative Maintenance

Performing periodic preventative maintenance on your Rascal AutoGo will ensure long, useful operational life as well as identifying any potential problems that may occur that might effect safe use and operation of the vehicle. Maintenance topics are presented in the following.

#### **Frame Inspection**

Periodically inspect the folding frame of the vehicle for cracks, fractures, or other damage. Any cracks/fissures should be noted and the vehicle removed from service.

## **WARNING!**

**DO NOT use vehicle if frame damage is present. Severe personal injury may result.**

Additionally, check conditions of reflectors mounted on frame. Replace any missing or damaged reflectors to maintain proper visibility.

### **Headlight**

Although the headlight of the dash uses a long-life halogen bulb, it may burn out, especially if left on for a long period of time, and require replacement.

Replacement involves removing top cover of the dash, removing the burned-out bulb, installing the replacement, and replacing the dash cover. Replacement bulbs are available directly from Electric Mobility Corp., or from your authorized service center.

**Note:** Headlight is a 24V 5W unit and is generally not available at local supply stores.

### **Lubrication**

Under normal operating conditions, the Rascal AutoGo requires no special lubrication or grease. The drivetrain gearbox is a sealed unit. Bearings, joints, fasteners and other moving parts are protected by self-lubricating components so periodic lubrication is generally not necessary.

Due to environmental conditions, movement may become stiff and difficult. If movement becomes difficult, use of a spray lubricant can be used to restore easy movement. Use a spray lubricant such as VVD-40. Use lubricant sparingly and avoid contact with vinyl or painted surfaces.

### **Tires**

Front and rear tires of the Rascal AutoGo are foam-filled and do not require air pressure. Tires should, however be checked periodically for damage, cuts, flat-spots, or excessive tread wear. Damaged tires should be replaced.

### **Electrical Connections**

Check wiring connector at the drivetrain to make sure that a tight connection is made. If Battery Pack terminals (both terminals within tiller and recharger plug terminals) are corroded, disconnect Battery Pack and clean all connections with a soft wire brush. Re-connect leads and apply a protective coating (e.g., petroleum jelly, etc.) to prevent corrosion.

### **Hardware Inspection**

Check and make sure all fasteners are present and secure.

### **Cleaning Instructions**

Wash your Rascal AutoGo with a sponge using household detergent diluted in warm water to clean all components. Wipe excess soapy water from the vehicle using a clean damp cloth. Avoid getting any water on the electrical components (i.e., connectors, switches, Battery Pack terminals, etc.).

### **Polishing**

Polish all plastic components to help protect them from scratches and a dull finish. This can be done by using a non-abrasive auto polishing material available at your local automotive parts dealer or local department store (automotive section). Make sure to clean the surface first with an auto body cleaner using a soft cotton cloth and dry before polishing. To bring out the shine, follow the manufacturer's instruction on the polishing material.

### **Cable Adjustment**

The cable that actuates the front wheel lock used in folding up the vehicle includes an adjustment to keep cable under proper tension. This adjustment is shown in Illustration 17. Turn counter-clockwise to loosen and clockwise to tighten.

When dash pivoting and/or front wheel lock operation is too tight or too loose, adjust cable tension accordingly. A small, open-ended hex wrench can be used on the turnbuckle.

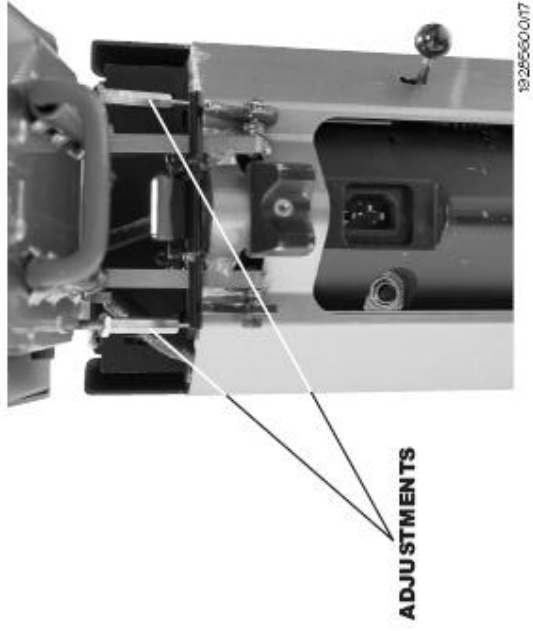

Illustration 17 — Cable Turnbuckle Adjustment

### **Drivetrain**

The parking brake of the drivetrain includes an adjustment setscrew for the brake pad.

If brake starts to squeal, tighten setscrew. Brake nut should be set 1/6" (1.5 mm) from brake pad. Periodically clean dirt in brake pad by blowing dirt out with air pressure hose.

If brake release lever becomes difficult to move, lubricate with a light oil or spray lubricant. Be careful not to get oil onto the brake pad.

### **Seat Frame Cams**

The two cams on the seat frame may require periodic tightening to ensure positive, locking action. Adjustment is from beneath using a slotted ball detent.



### **Replacing Clock Battery**

After time, the dash clock may begin to lose time, or stop, when the battery runs down. The battery is easily replaced by removing the clock from the dash, prying open the clock's case, and inserting a new battery. Battery location is shown in Illustration 18. Use the following to replace the clock battery.

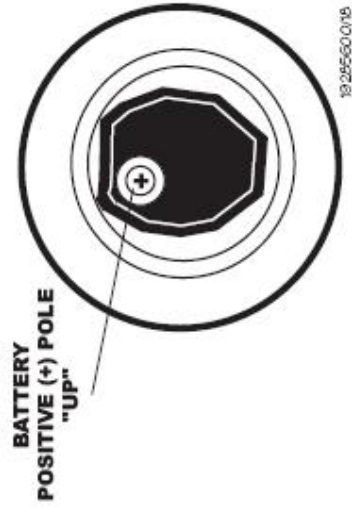

*Illustration 18 — Replacing Clock Battery*

**Battery Types: SR626SW, UCC 377, Ray-O-Vac RW329**

1. Remove clock from the dash by gently prying the edge of the clock from the dash.
2. Use a small screwdriver to open the case by inserting the screwdriver blade into the notch on the back cover. Gently twist blade so that the back cover comes off.
3. Slide the metal battery cover plate aside and remove battery.
4. Install new battery with positive pole (+) facing outwards. Slide battery cover back in place over new battery.

After replacing battery, make sure time setting is correct before replacing clock into dash.

## Troubleshooting Guide

This table is only a guide to aid you in getting your vehicle operating, should you have any problems. If you are unable to get your vehicle operating, call either Electric Mobility Customer Service toll free number located at the front of this manual or your local Authorized Service Center.

<b>Symptom</b>	<b>Possible Cause</b>	<b>Solution</b>
<b>Unit does not move</b>	<ol style="list-style-type: none"> <li>1. Keyswitch not "ON"</li> <li>2. Manual release in 'Push Mode'</li> <li>3. Battery power low</li> <li>4. Drivetrain not connected to frame</li> <li>5. Vehicle shuts down to conserve battery</li> </ol>	<ol style="list-style-type: none"> <li>1. Turn keyswitch to "ON"</li> <li>2. Lift brake lever to 'Ride Mode'</li> <li>3. Recharge batteries</li> <li>4. Push down on frame until drivetrain clicks into place.</li> <li>5. Cycle keyswitch</li> </ol>
<b>Vehicle feels wobbly when driven</b>	<ol style="list-style-type: none"> <li>1. Tire damaged</li> <li>2. Seat is loose</li> </ol>	<ol style="list-style-type: none"> <li>1. Replace tire</li> <li>2. Check seat for loose hardware or damage and assure latch is closed around seat frame</li> </ol>
<b>Range less than expected</b>	<ol style="list-style-type: none"> <li>1. Charging too infrequently</li> <li>2. Defective or worn out battery</li> <li>3. Cold weather reduces battery life</li> </ol>	<ol style="list-style-type: none"> <li>1. Charge unit more often</li> <li>2. Load test batteries. If necessary replace</li> <li>3. Allow batteries to reach room</li> </ol>

---

	4. Defective charger	temperature and then fully recharge 4. Contact Electric Mobility or your Authorized Service Center
<b>Erratic behavior when engager operated</b>	1. Faulty engager 2. Defective wiring harness	1. Contact Electric Mobility or your Authorized Service Center 2. Replace harness
<b>Battery Pack LED not lit</b>	1. Cord not properly plugged-in 2. Faulty charger	1. Verify cord correctly plugged-in at both Battery Pack and electrical outlet 2. Contact Electric Mobility or your Authorized Service Center
<b>Brake squeals</b>	1. Setscrew loose 2. Dirt in brake pad	1. Tighten setscrew - Brake nut should be set 1/6" from brake pad 2. Blow dirt out with air pressure hose
<b>Brake release lever sticks</b>	1. Rust and corrosion	1. Spray ball detent area with lubrication oil. Be careful not to get oil onto the brake pad
<b>Stiffness in steering</b>	1. Possible grime build up 2. Bearings in head tube worn	1. Lubricate bearings 2. Replace bearings

---

## Controller Fault Codes

In addition to the troubleshooting information in the previous section, the controller used in the Rascal AutoGo provides diagnostic information through means of a Fault Code Display that appears on the Battery Gauge. When a fault is detected, selected segments of the Battery Gauge will light to indicate the faults. Codes and faults are listed in the following.

<b>Battery Gauge LED Segment Lit</b>	<b>Meaning and What To Do</b>
<b>1</b>	Battery needs recharging or bad connection with battery. Check connections, recharge battery.
<b>2</b>	Bad motor connection. Check all connections between controller and motor.
<b>3</b>	Short circuit between motor and battery connection. Contact authorized service facility.
<b>4 &amp; 5</b>	(not used)
<b>6</b>	Controller inhibited from operation. Disconnect battery charger.
<b>7</b>	Throttle fault. Engager levers must be in neutral (centered) position before vehicle is turned on. Switch vehicle off, center levers, and switch back on.
<b>8</b>	Controller fault. Check all connections.
<b>9</b>	Bad parking brake connection. Check parking brake and motor connections.
<b>10</b>	Excessive voltage detected at controller. Check battery connections.

## **Parts Ordering Procedures**

To help us serve you as quickly as possible have your phone number, vehicle serial number or your order number ready when you call.

When ordering parts, please have your method of payment ready (i.e., credit card number and expiration date, check, etc.). All parts are shipped UPS Ground. Alternate shipping arrangements may be made for an additional charge based on weight and destination (i.e. UPS Next Day, UPS 2nd Day, etc.).

## **Accessories**

Your Rascal AutoGo can include several useful accessories to make your riding experience more enjoyable, convenient, and easier. These accessories can include:

- Electric Trunk Lift
- Trunk Lift Bracket
- AutoRack - Vehicle Carrier
- Storage Bags
- Vehicle Cable Lock
- Portable Ramps
- Cane, Crutch, and Oxygen Tank Holders
- Threshold Ramps
- Safety Flag & Holder
- Taillights
- Seat Belts
- Charger Cords for Different Countries
- Weather Cover

These accessories are available separately and come with complete instructions for installation and use with your vehicle. Contact your Customer Service representative for further information.

## Specifications<sup>1</sup>

### Dimensions:

Length	41-42" (104-106 cm)
Width	21" (53.3 cm)
Height	37" (94 cm)
Folded, Vertical	38" (96.5 cm) H x 21" (53.3 cm) W x 22" (55.8 cm) L
Folded, Horiz., w/Seat	23" (58.4 cm) H x 21" (53.3 cm) W x 38" (96.5 cm) L
Folded, Horiz., w/o Seat	21" (53.3 cm) H x 21" (53.3 cm) W x 38" (96.5 cm) L
Wheelbase	30.5" (77.4 cm)
Ground Clearance	2" (5 cm)
Footroom	15" 38.1 cm) L x 5" (12.7 cm) W

### Weights:

Frame	45 lb. (20.4 kg)
Battery Pack	22 lb. (9.9 kg)
Drivetrain	24 lb. (10.8 kg)
Seat	15 lb. (6.8 kg)

### Performance:

Speed <sup>2</sup>	4.2 mph (6.75 km/h)
Range <sup>2</sup>	Up to 10 miles (16 km)
Turning Radius	35" (89 cm)
Hill Climbing	12°
Weight Capacity	300 lb. (136 kg)

### Electrical:

Batteries	Two: 12V/15Ah
Battery Charger	2A
Charger Cord Length	3' (91.4 cm)
Controller	Digital with programmable slow mode

### Construction:

Frame	Two Piece, die-cast aluminum (chassis and footplate)
Dash	Aluminum with internal controller and dash wiring
Drivetrain	Single motor, rear wheel differential drive with automatic parking brake
Front Wheels	Two 7" (17.7 cm) x 1 3/4" (4.4 cm) Foam Filled
Rear Wheels	Two 9" (22.8 cm) x 3" (7.6 cm) Foam Filled
Seat	Lightweight, detachable folding padded seat with vinyl upholstery
Seat Height	21 1/4" (52 cm)
Seat Width	18" (45.7 cm)

<sup>1</sup> Due to continuous efforts to improve product design, specifications may change and products may vary slightly from photos throughout this manual.

<sup>2</sup> Range and speed vary with driving circumstances



## Warranty

The Rascal Company, warrants the vehicle, other than its component battery or batteries, to be free from defects in materials and workmanship for a period of one (1) year from the date of purchase. If, within such warranty period, any such product shall be proven to The Rascal Company, satisfaction to be defective, such product shall, at option, be repaired or replaced. Sole obligation and your exclusive remedy under this warranty shall be limited to such repair and/or replacement. This warranty includes parts and labor for one year and travel for 30 days. For warranty service, please contact The Rascal Company, at: 1-800-743-1302.

## LIMITATIONS AND EXCLUSIONS

The foregoing warranty shall not apply to products subjected to negligence, accidents, improper operation, maintenance or storage, commercial, institutional, or service use other than normal application, or to products damaged by reason of repairs or modifications made to any product without the specific written consent of The Rascal Company, or products damaged by circumstances beyond The Rascal Company, control. The foregoing warranty is exclusive and in lieu of all other express warranties, implied warranties, if any, including but not limited to the implied warranties of merchant ability and fitness for a particular purpose. The warranty shall not extend beyond the duration of the express warranty provided herein. The Rascal Company, shall not be liable for any consequential or incidental damages whatsoever.



